



Passenger Impact Program

Rider Experience and Operations Committee

2/6/2025



Why We Are Here

Upcoming Work Requiring Service Disruption

- Operation Chilly (Q1 2025)
- Downtown Tunnel Resiliency Package (Q1 2025)
- Pinehurst Station Stairwell (Q2 2025)
- Look ahead to Remainder of 2025 & 2026

The purpose of this presentation is for information only.

No Board action is expected today.

Work in Q1 2025 – Operation Chilly Overview

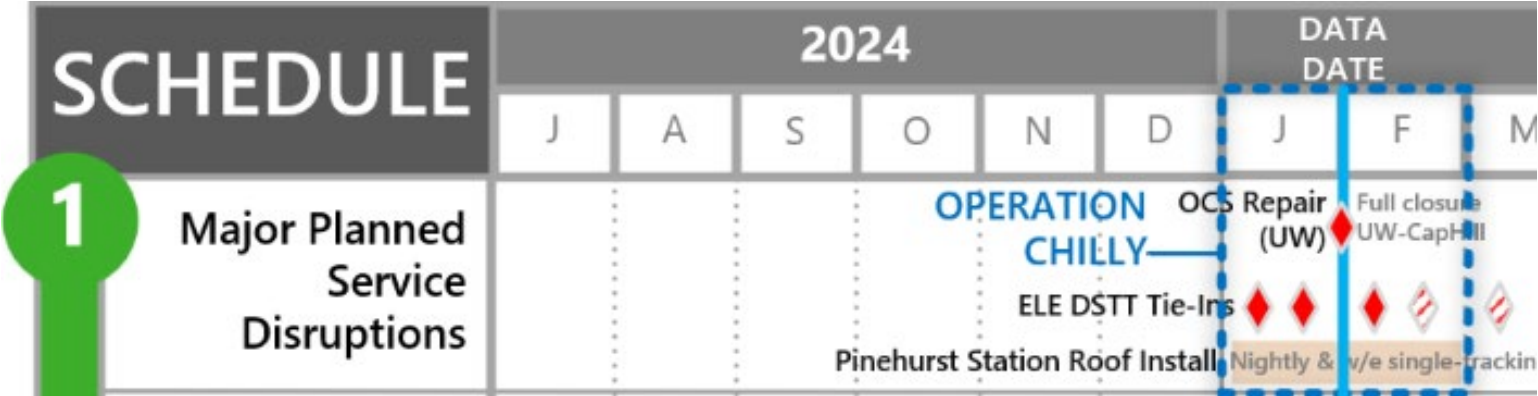

Work in Q1 2025 – Operation Chilly

Pinehurst Station Roofs

- **Why this is necessary:** Install roofing material on the station roofs
- **Passenger benefit:** Maintain life of the station
- **What is the impact:**
 - Jan 4 to Feb 27
 - Single tracking with 12-minute headways
 - Weekdays 5:30 pm to close of service
 - Select weekends
 - Work proceeding on plan



Work in Q1 2025 – Operation Chilly

2 Line Downtown Tunnel Signal & Electrical Integration

- **Why this is necessary:** Complete work to tie in 2 Line signal and electrical systems to downtown tunnel and perform full systems integration testing.
- **Passenger benefit:** 2 Line operations start safely and on schedule.
- **What is the impact:**
 - January 10 to 12 – bus bridge Westlake to SoDo - complete
 - January 17 to 19 – bus bridge Cap Hill to SoDo - complete
 - February 14 to 16 – bus bridge Cap Hill to SoDo
 - February 21 to 23 – contingency weekend



Work in Q1 2025 – Operation Chilly

2 Line Downtown Tunnel Signal & Electrical Integration

- **February 14 to 16**
Cap Hill to SoDo
- **February 21 to 23**
Cap Hill to SoDo
(contingency)

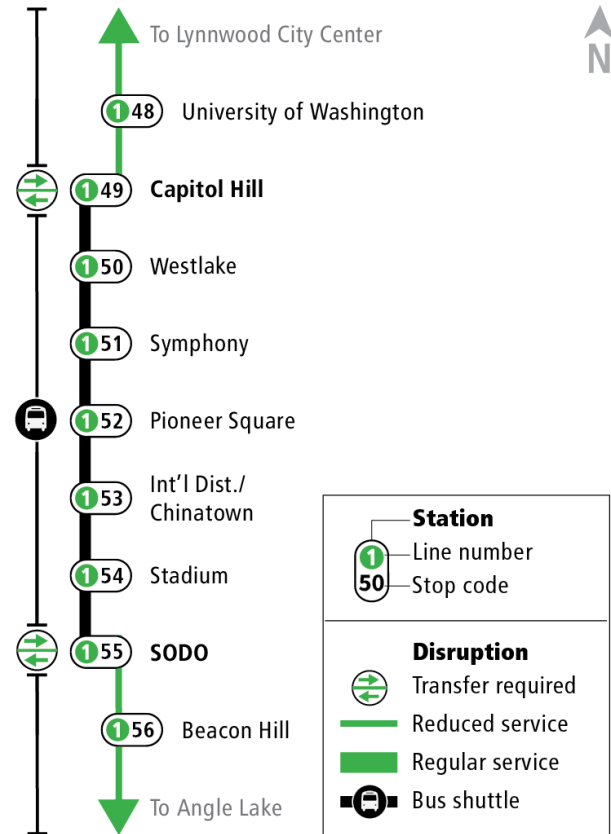

Work in Q1 2025 – Operation Chilly

Repaired OCS Wire Near UW Station

- **Why this is necessary:** Repaired overhead train power and improve a section of wire that's wearing too fast
- **Passenger benefit:** Trains back to normal speed in this area, and likelihood of future impacts is reduced
- **What is the impact:**
 - Work was completed on Feb 2
 - Additional resiliency repairs were done during the closure

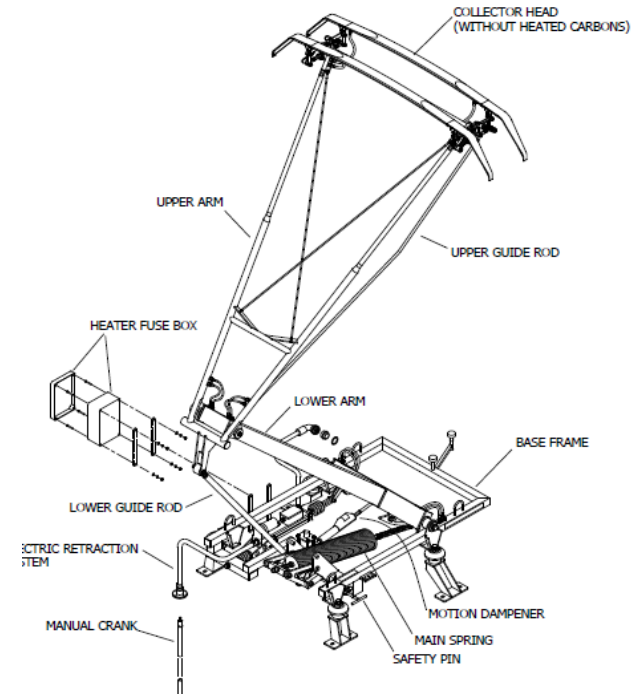

Work in Q1 2025

Downtown Tunnel Resiliency Package

- **Why this is necessary:** Perform multiple projects in the downtown tunnel
- **Passenger benefit:** Accelerate resiliency work
- **What is the impact:**
 - One weekend of downtown tunnel full closure
 - Make use of an Operation Chilly contingency weekend if not needed for Eastlink
 - Bus shuttle will replace service downtown



Work in Q2 2025

Pinehurst Station Stairwells

- **Why this is necessary:** Finalize stairwell construction near OCS
- **Passenger benefit:** Complete station access points
- **What is the impact:**
 - Pending for April 2025
 - Up to 4 weeks of work
 - Single tracking with 12-minute headways
 - Weekdays 5:30 pm to close of service



Look Ahead to Remainder of 2025/26

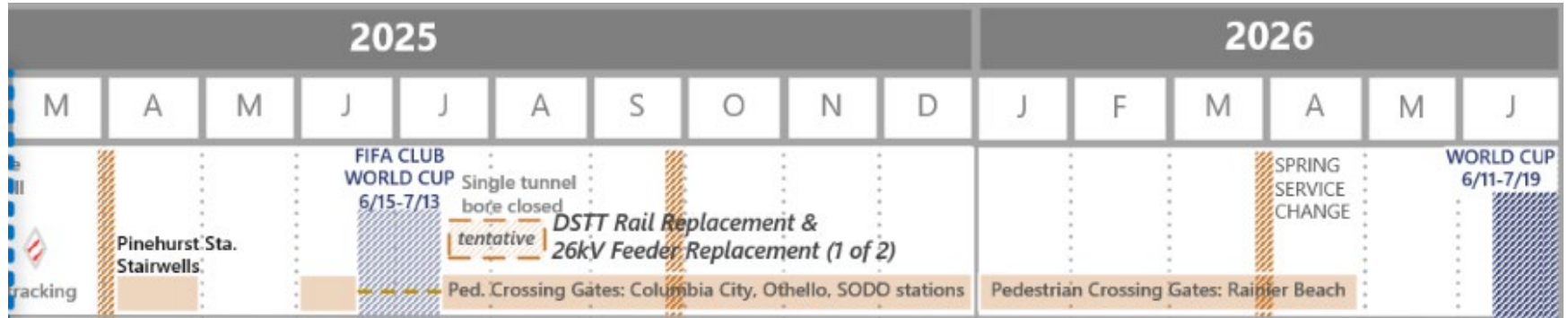

Next Steps

- Continue to gather lessons learned from Operation Chilly impact improve service to passengers during future impacts
- Schedule spring impacts to avoid community events
- Continue planning impacts for the remainder of 2025 and 2026

Thank you.



 [soundtransit.org](https://www.soundtransit.org)

